

STEP 1

■INSTALL: 20 splices

Connection table Module1

Module1:Campus Backbone Cabling

FODB-1 Wall mount

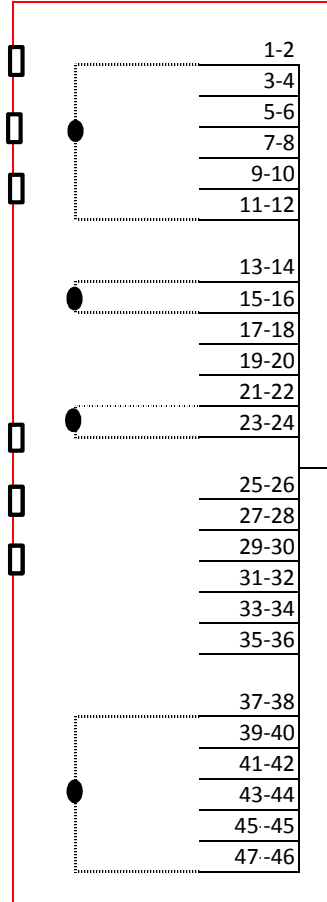

Number of Fusion Splice: 8

Loose Tube Cable(48)

【FO-2】

Loose Tube Cable(48)

【FO-2】

Testing visual light source:
 Test if the light travels from Port A to B.
Note: At least two Experts will have to be with the test.

19-inch Rack
1F

【FO-6】

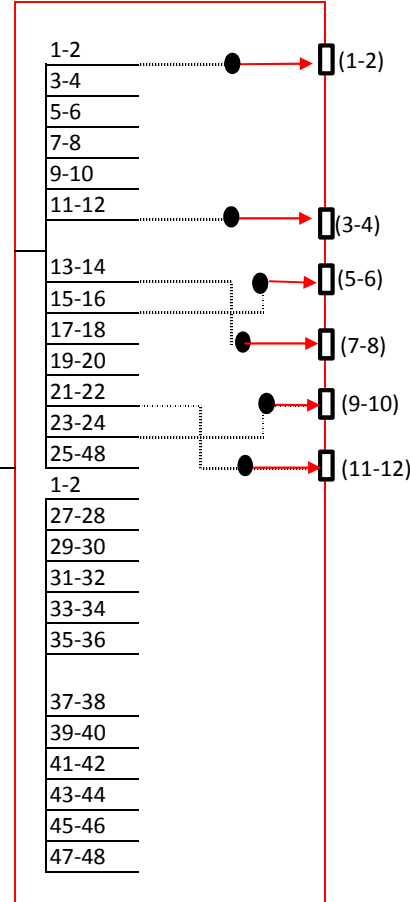

Number of Fusion Splice: 12
 Number of Patch Cord: 2 Duplex

Port A

Port 3 to 7

Port B

Port 5 to 11

STEP 2

Connection table Module1

■INSTALL: 16 splices

Module1:Campus Backbone Cabling

FODB-1 Wall mount

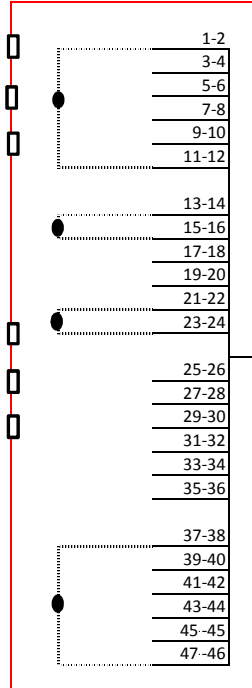

Number of Fusion Splice: 8

FO Closure for Underground

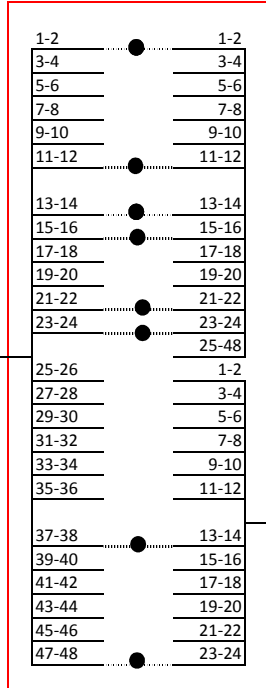

Number of Fusion Splice: 16

19-inch Rack
1F

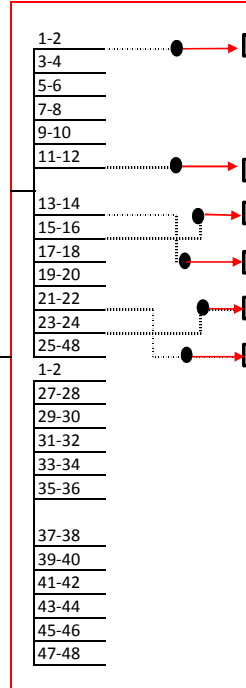

Number of Fusion Splice: 12
Number of Patch Cord: 2 Duplex

Loose Tube
Cable(48)
【FO-2】

Loose Tube
Cable(48)
【FO-2】

Loose Tube
Cable(24)
【FO-1】
OPEN

Port 5 to 7

Port 5 to 11

Testing Loss:

Test and save your fiber ports results between Port A and Port B, according to the measurement guideline.

using the DSX5000 with the appropriate settings and save (1 Jumper Method):

Fiber link for Port A
{Save Name as : "F-1F-A1", "F-1F-A2"}

wavelength: 1550nm and 1310nm
bidirectional setting
maximum loss: 4.5 dB

STEP 3

Connection table Module1

■INSTALL: 4 splices

Module1:Campus Backbone Cabling

FODB-1 Wall mount

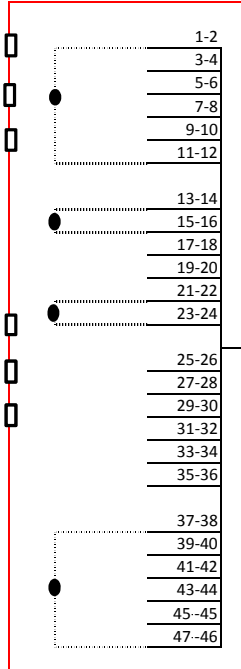

Number of Fusion Splice: 8

FO Closure for Underground

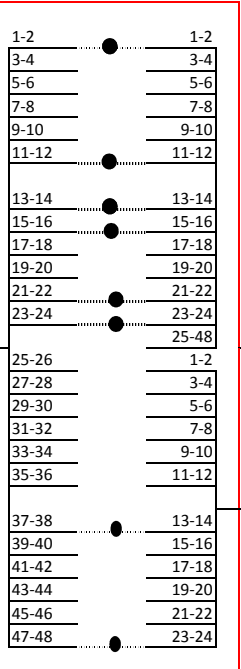

Number of Fusion Splice: 16

19-inch Rack
1F

【FO-6】

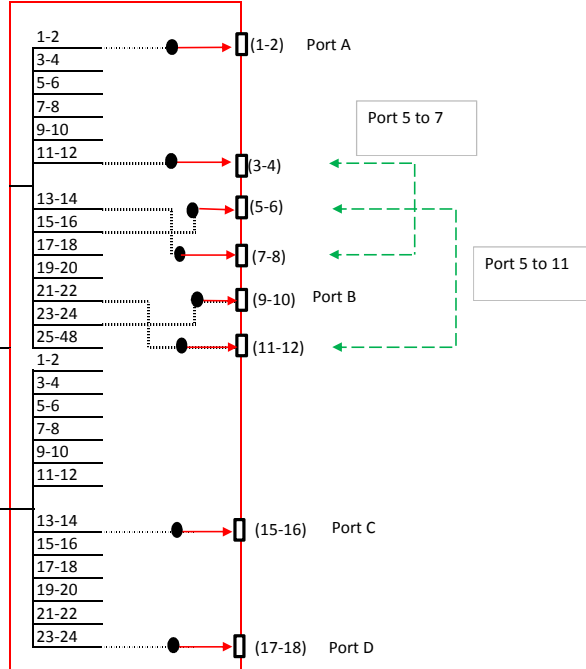

Number of Fusion Splice: 16

Number of Patch Cord: 2 Duplex

Loose Tube
Cable(48)
【FO-2】

Loose Tube
Cable(48)
【FO-2】

Loose Tube
Cable(24)
【FO-1】

Testing OTDR:

Test and save your fiber ports results between in Port C and Port D, according to the measurement guideline.

using the DSX5000 with the appropriate settings and save:

Fiber link for Port C
{Save Name as : "F-1F-C1, "F-1F-C2"}

Fiber link for Port D
{Save Name as : "F-1F-D1, "F-1F-D2"}

wavelength: 1550nm and 1310nm
bidirectional setting
maximum loss: 1.5 dB

Annex 1: Fig.1 Schematic View of Module 1 and 2

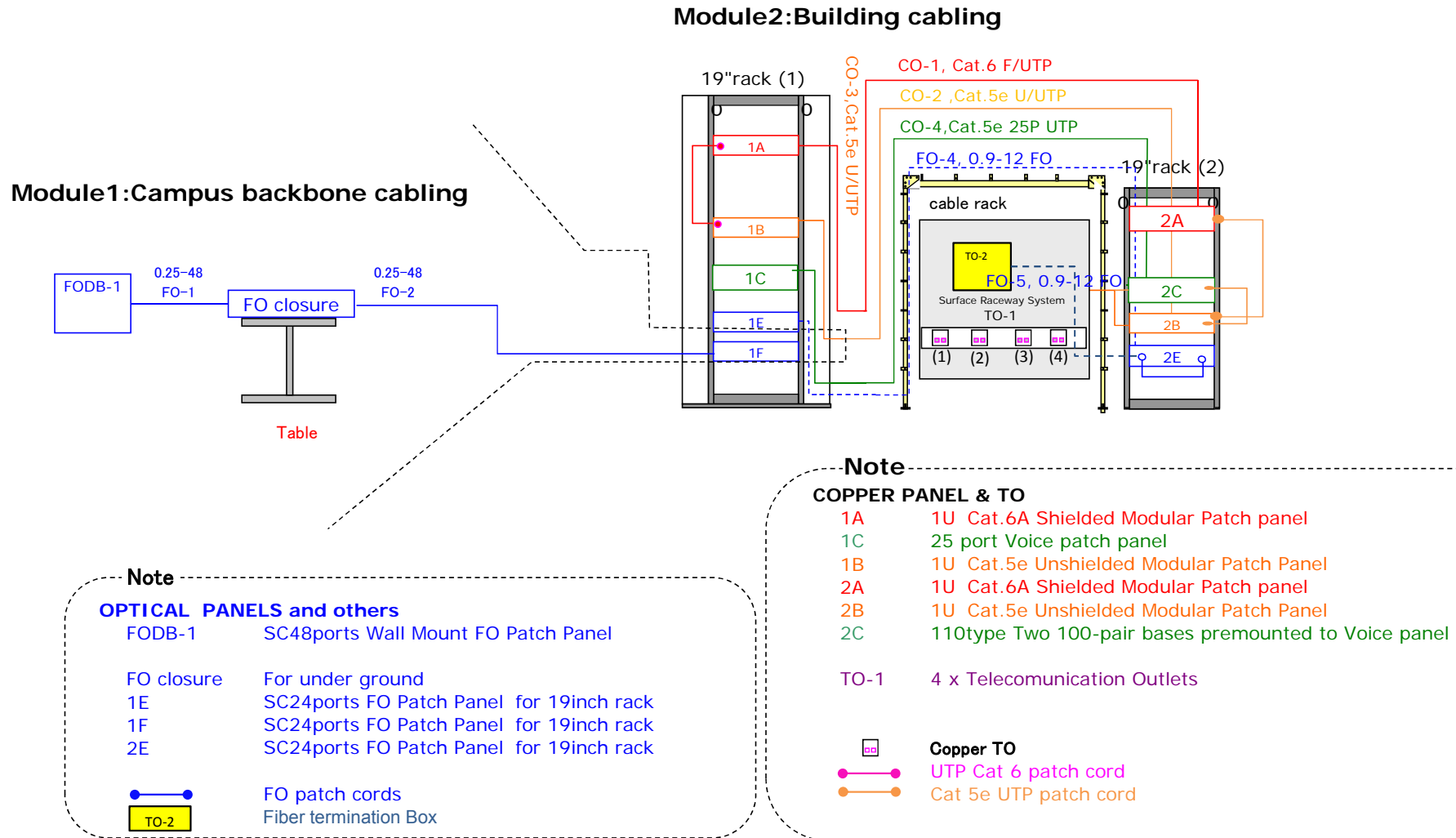

Layout for TO-1 and TO-2

Side View of Platform

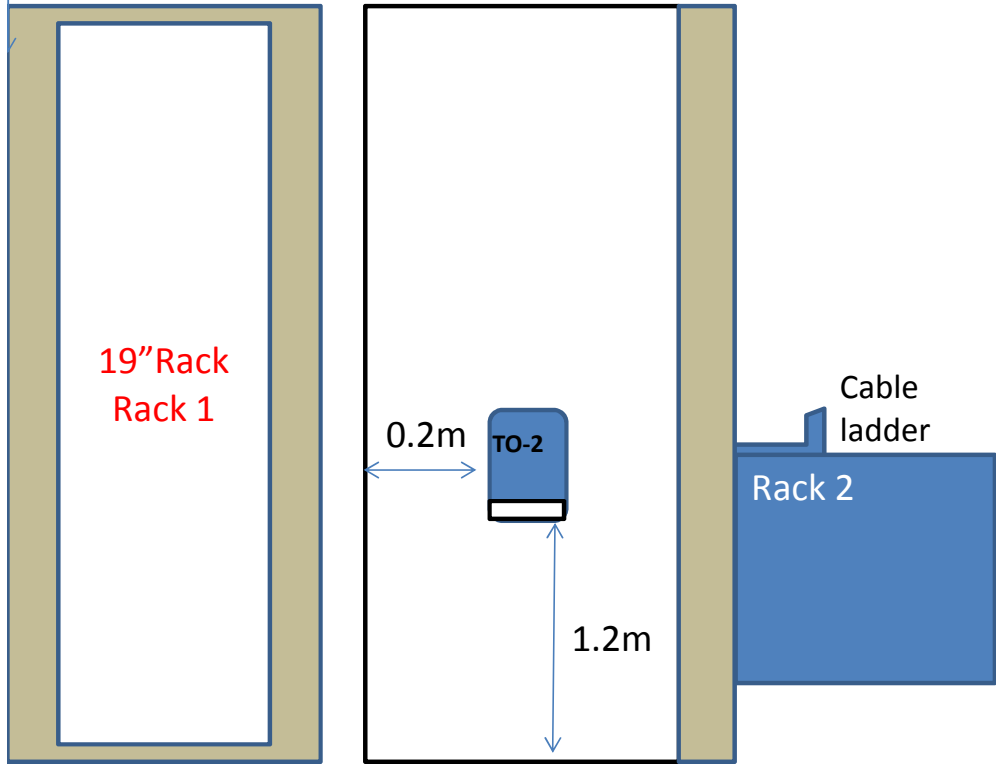

Front View of Platform

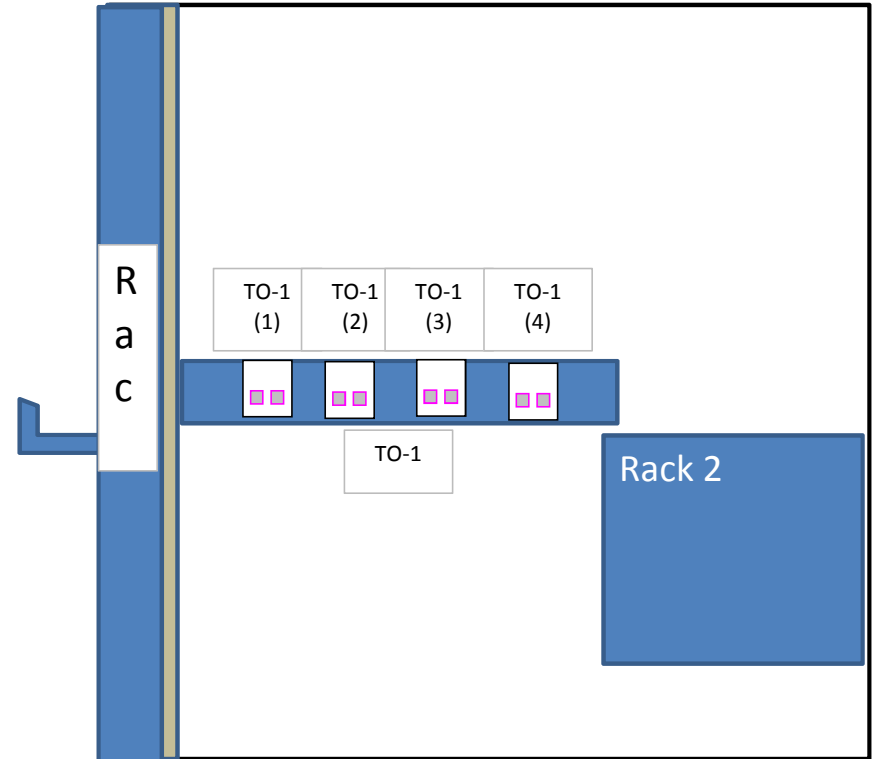

Note: Position is approximate, need to be confirm by shopmaster on Booth layout

Module2: Building Cabling

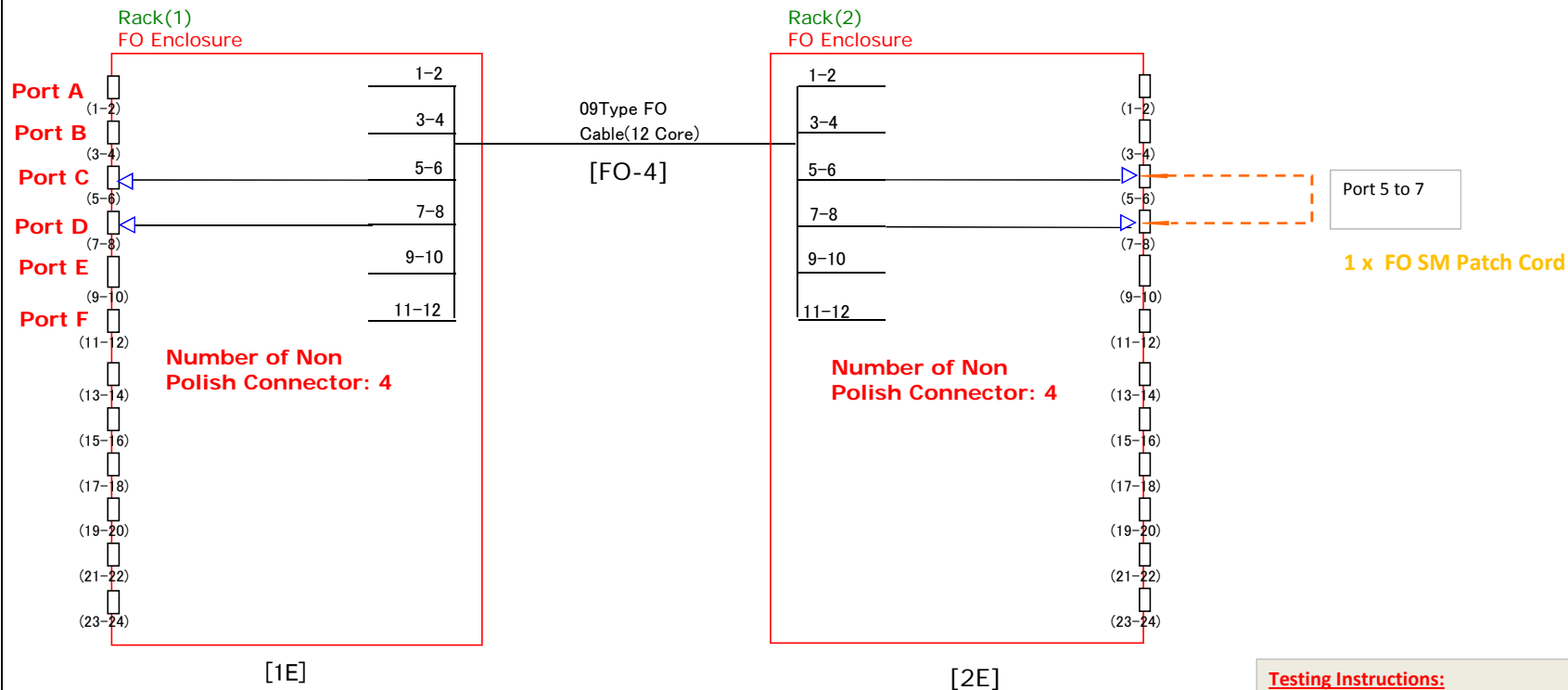

Testing Instructions:
 Test and save your fiber ports results using the DSX5000 with the appropriate settings (1 Jumper Method) for the following:
 a. Fiber link for Port C
 {Save Name as : "F-1E-C1", "F-1E-C2"}
 b. Fiber link for Port D
 {Save Name as : "F-1E-D1", "F-1E-D2"}
 Note: Experts will verify the test results during judging.

Legend

	:Non Polish SC Connector		:Optical Patch Cord
	:Fusion Splice		:One side Optical Patch Cord
	:Mechanical Splice		:Optical SC Adapter

DRG. No.	Fig.4	
TITLE	Optical fiber connection	
Information Network Cabling		Module 2

Module2: Floor Distibution

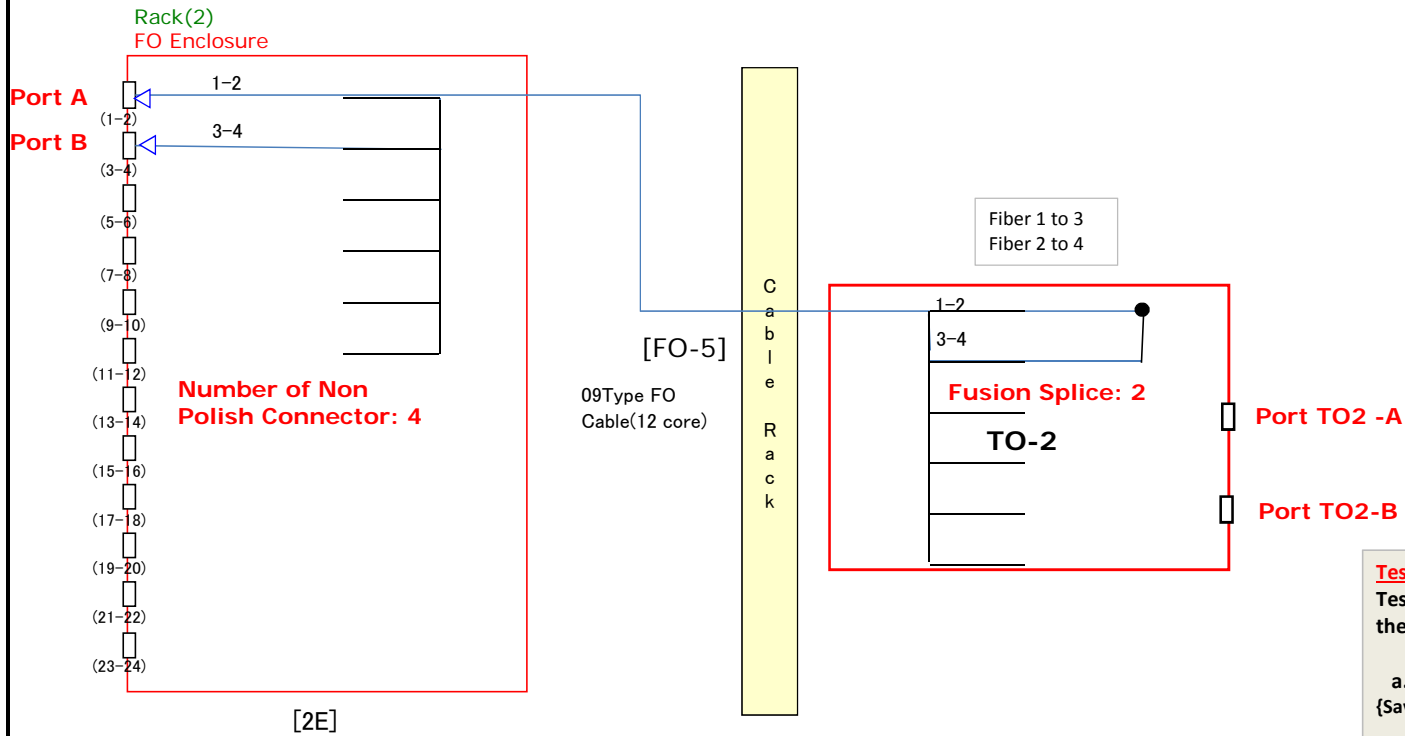

Testing Instructions:
 Test and save your fiber ports results using the DSX5000 with the appropriate settings (1 Jumper Method) for the following:

a. Fiber Link for Port A
 {Save Name as : "F-2E-A1", "F-2E-A2"}

Note: Experts will verify the test results during judging.

Legend

	:Non Polish SC Connector		:Optical Patch Cord
	:Fusion Splice		:One side Optical Patch Cord
	:Mechanical Splice		:Optical SC Adapter

DRG. No.	Fig.4	
TITLE	Optical fiber connection	
Information Network Cabling		Module 2

Annex 6:

[CO-1] *6 * 20 meters
F/UTP Cat.6A

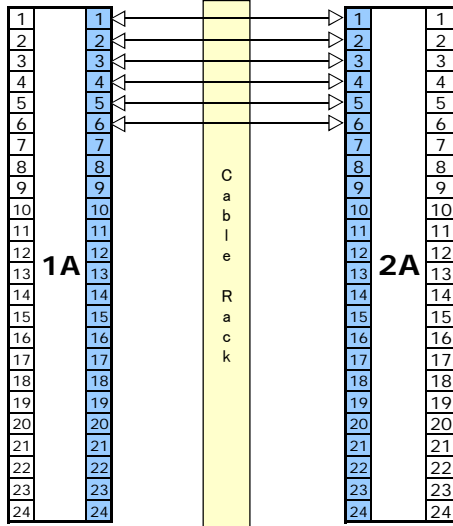

[CO-2] *12
U/UTP Cat.5e

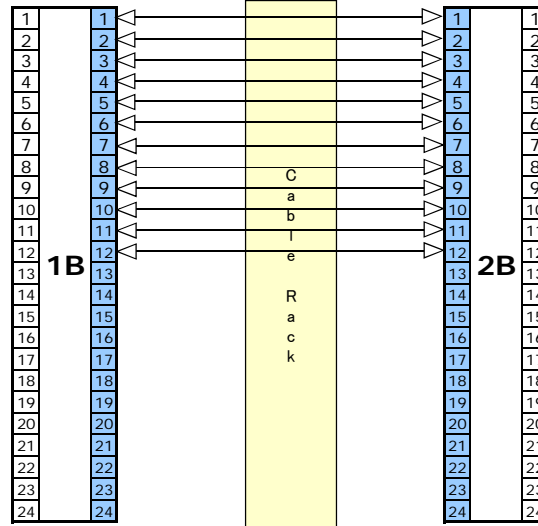

Legend

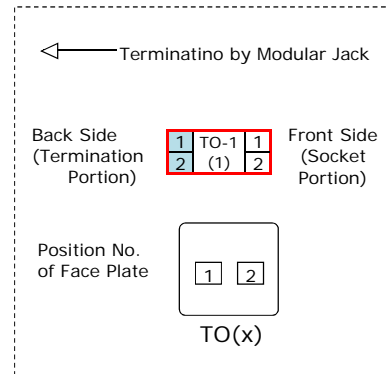

[CO-3] *6
U/UTP Cat.5e

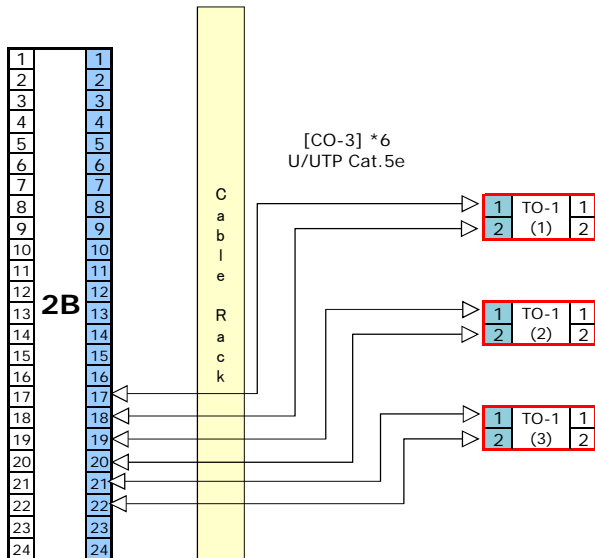

Testing Instructions:

Test and save your copper ports results using the DSX5000 with the appropriate settings base on the ports that experts have indicated during competition day.

- Permanent lnk test for the following:
- a. Panel 1B to 2B (all ports to be saved)
(Save format as "C-1B-Port_no")
 - b. Panel 2B to TO (all ports to be saved)
(Save format "C-2B -Port_no")
 - c. Panel 1A to 2A (all ports to be saved)
(Save format as "C-1A- Port_no")
- Note: Experts will verify these ports results during judging.

DRG.No.	Fig.6
TITLE	Schematics draw of Twisted-pair cabling
Information Network Cabling	Module 2

Annex 7:

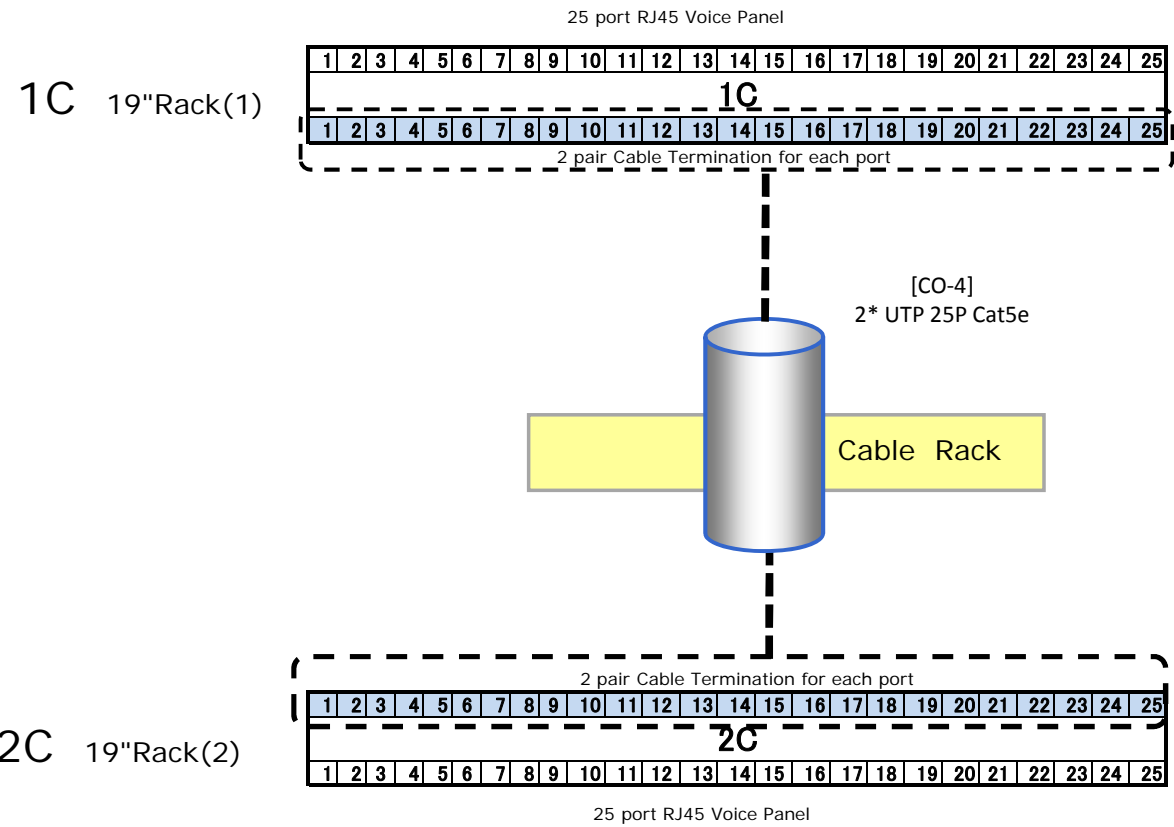

Testing Instructions:

Testing result not required. Wire Map must be accurate.

Note: Experts will verify only wire map for these Cat 3 ports results..

legend

:Cable

:2 pair Cable Termination for each port

1	2	3
1	2	3

Back of voice panel

Front of voice panel

DRG.No.	Fig.7
TITLE	Schematics draw of Voice cabling
Information Network Cabling	Module 2

Factory Terminated Patch cord is provided

3 x U/UTP Cat.5e
Patch-cord 2m

3 x U/UTP Cat.5e
Patch-cord 2m

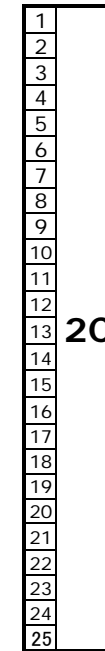
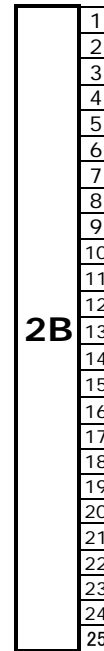
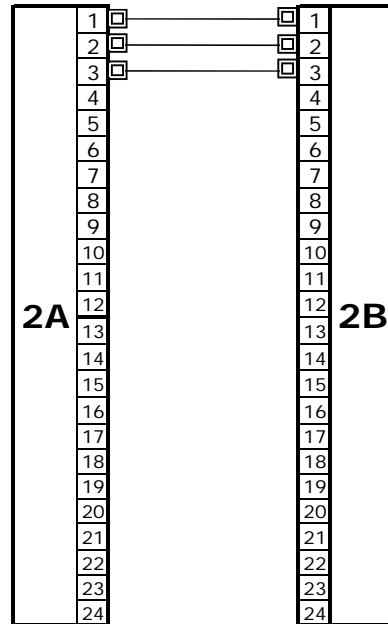
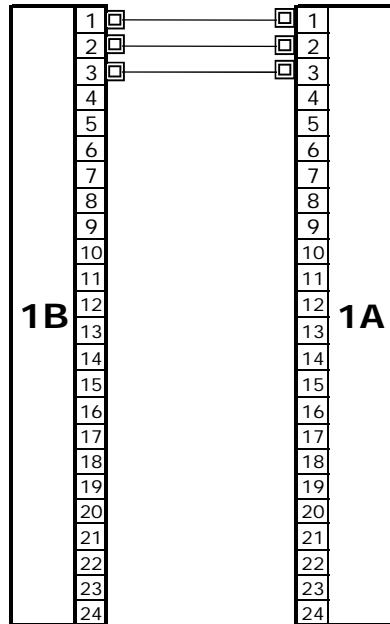

Legend

Factory Terminated Patch cord is provided

Patch-cord[Cat.5e]

Patch-cord[Cat.6Cat.6]

DRG.No.	Fig.6	
TITLE	Schematics draw of Patch-cords	
Information Network Cabling	Module 2	

Annex 10:

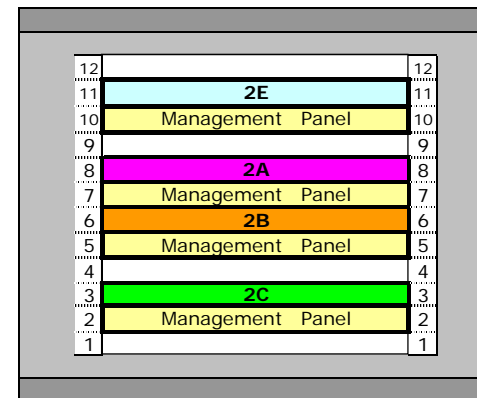
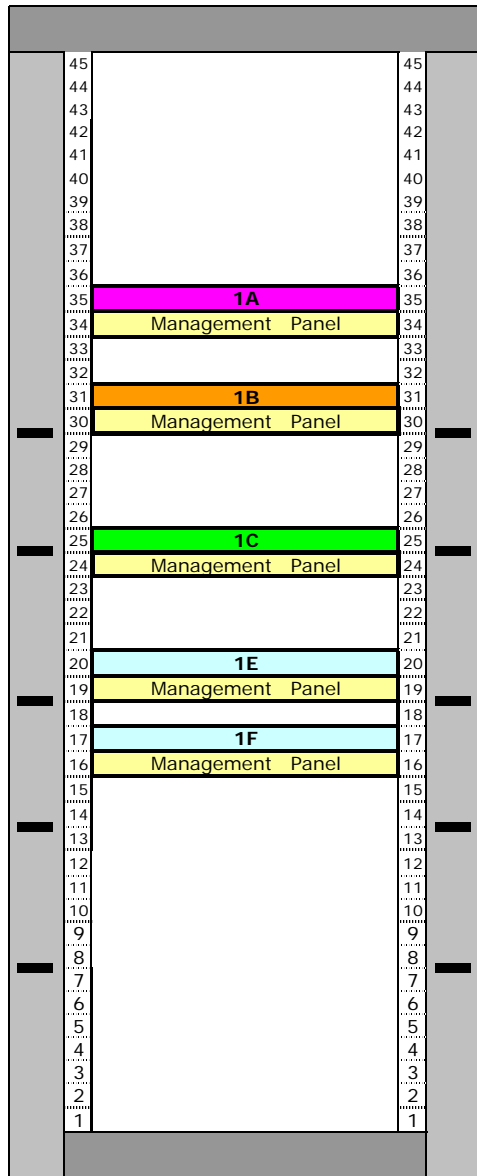

DRG. No.	Fig. 10
TITLE	Mounting
Information Network Cabling	

Module2: Building Cabling

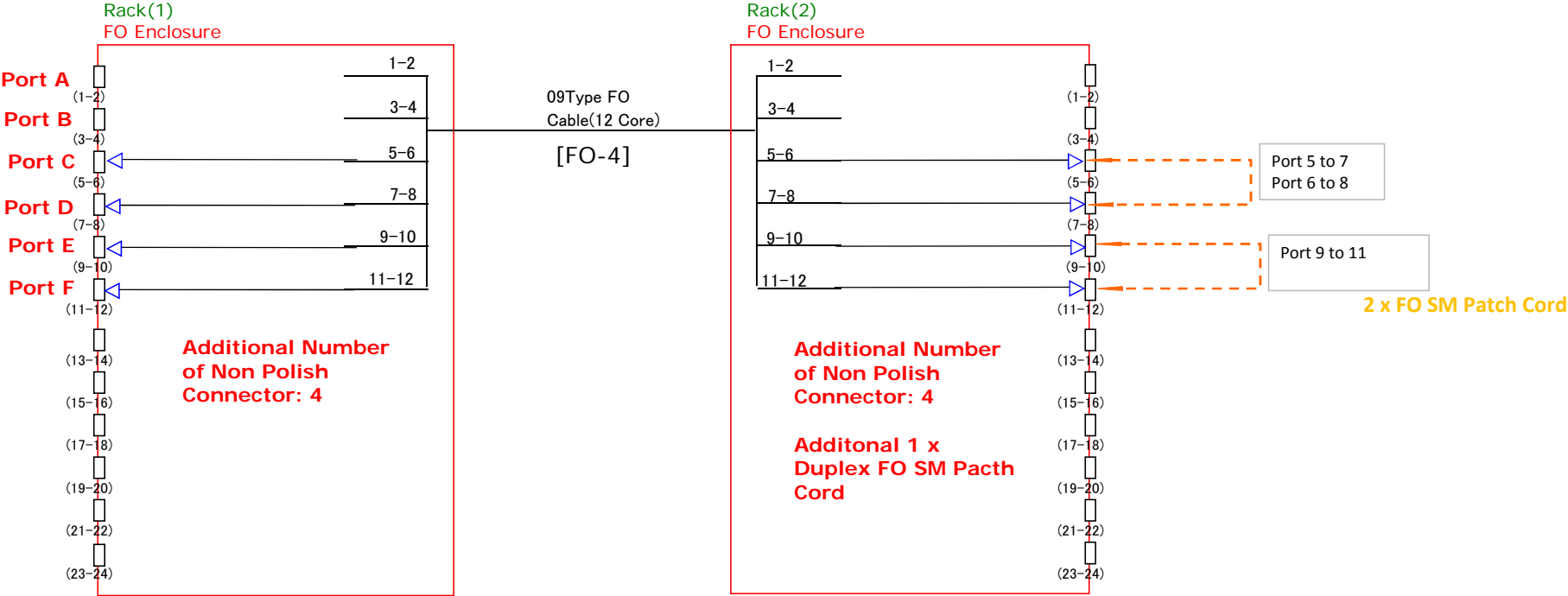

Optional Testing Instructions:
Test and save your fiber ports results using the DSX5000 with the appropriate settings (1 Jumper Method) for the following:

- a. Fiber link from Port E
 {Save Name as : "F-1E-E1", "F-1E-E2"}
- b. Fiber link from Port F
 {Save Name as : "F-1E-F1", "F-1E-F2"}

Note: Experts will verify the test results during judging.

DRG. No.	Fig 11	
TITLE	Optional Task 1	
Information Network Cabling	Module 2	

Optional 2

Module2: Floor Distribution

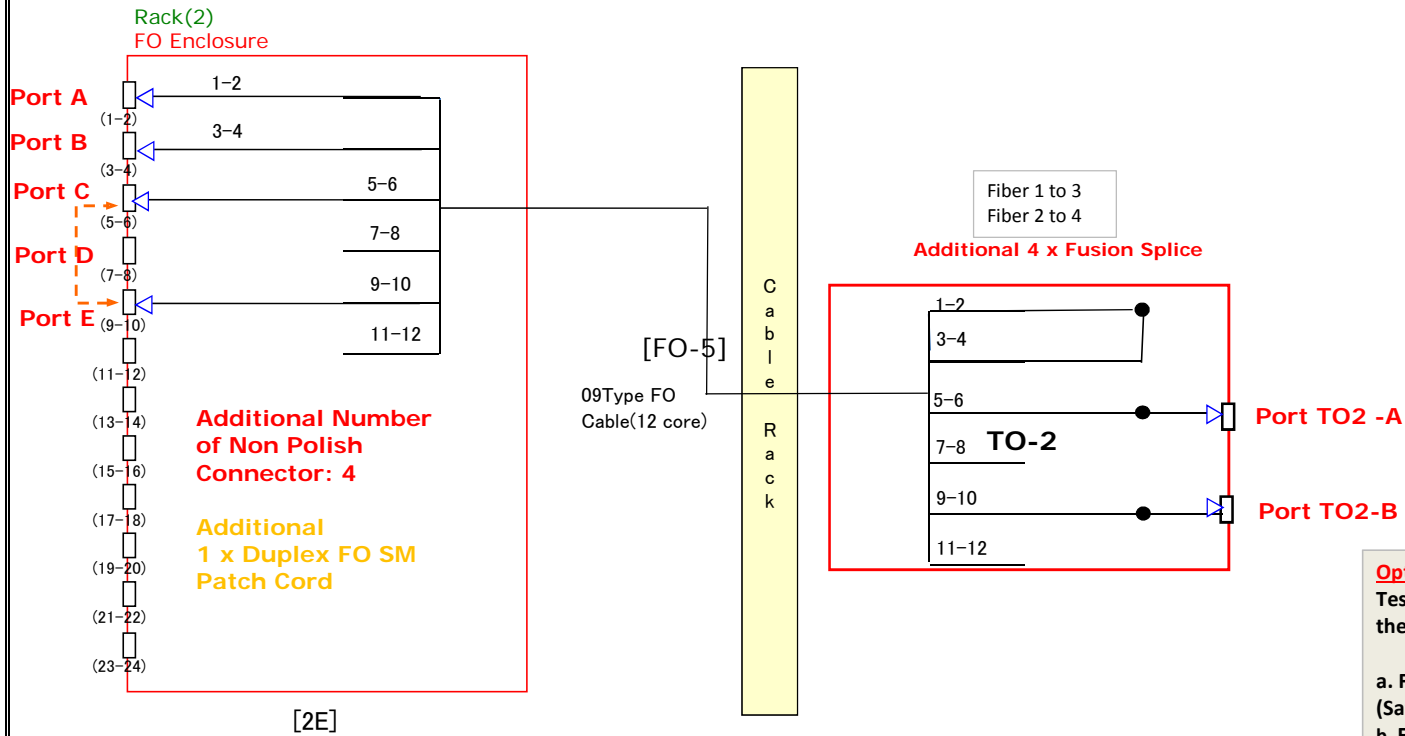

Optional Testing Instructions:
 Test and save your fiber ports results using the DSX5000 with the appropriate settings (1 Jumper Method) for the following:

- a. Fiber Link Port C
(Save Name as: F-2E-C1, F-2E-C2)
- b. Fiber Link Port E
(Save Name as: F-2E-E1, F-2E-E2)

Note: Experts will verify the test results during judging.

Legend

◁	:Non Polish SC Connector	↔	:Optical Patch Cord
●	:Fusion Splice	←	:One side Optical Patch Cord
■	:Mechanical Splice	□	:Optical SC Adapter

DRG. No.	Fig 12	
TITLE	Optional 2	
Information Network Cabling		Module 2

[CO-1] *6 * 20 meters
F/UTP Cat.6A

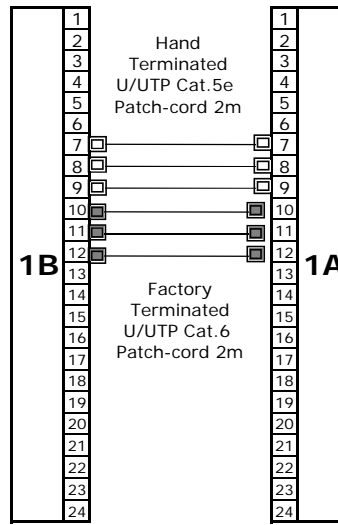
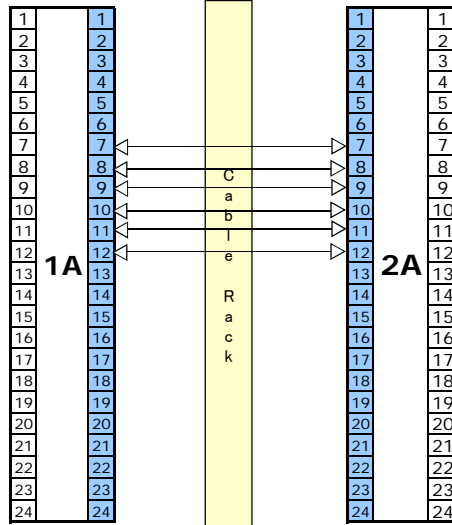

Optional 3

Legend

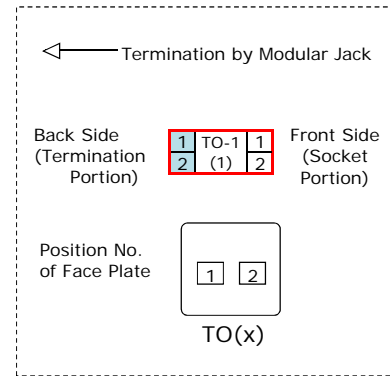

Testing Instructions:

Test and save your copper ports results using the DSX5000 with the appropriate settings base on the ports that experts have indicated during competition day.

Permanent link test for the following:

- a. Panel 1A to 2A (All ports that has been changed to be saved)
Save format as "C-1A-PortNo"

Note: Experts will verify these ports results during judging.

DRG.No.	Fig. 13
TITLE	Optional Task 3
Information Network Cabling	Module 2

[CO-2] *12
U/UTP Cat.5e

Optional 4

Testing Instructions:

Test and save your copper ports results using the DSX5000 with the appropriate settings base on the ports that experts have indicated during competition day.

Permanent link test for the following:
a. Panel 1B to 2B (Ports that has been change to be saved)
(Save format as "C-1B-PortNo")

Note: Experts will verify these ports results during judging.

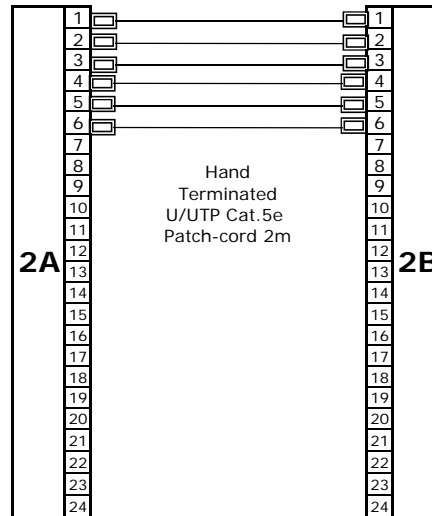
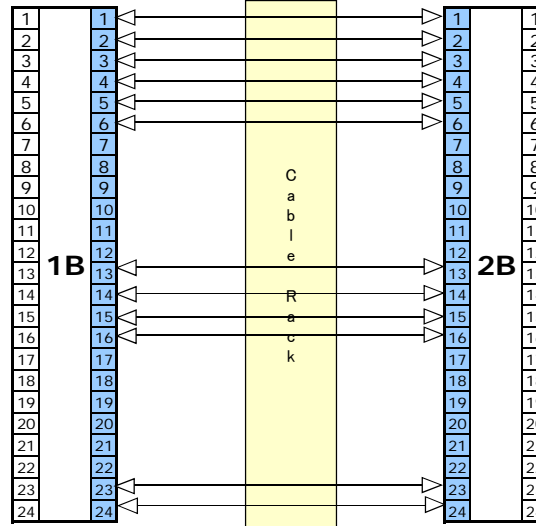

Legend

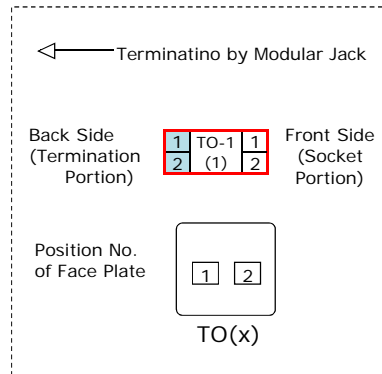

DRG.No.	Fig 14
TITLE	Optional Task 4
Information Network Cabling	Module 2

Skill name
Information Network Cabling
Criteria

	Criteria	Mark
A	Module 1	27.00
B	Module 2	40.00
C	Module 3	21.00
D	Module 4	5.00
E	Module 5	7.00

Sub Criteria ID	Sub Criteria Name or Description	Aspect Type O = Obj S = Sub J = Judg	Aspect - Description	Judg Score
A1	Module 1 ; Understanding test project			
A2	Module 1 : Cable management	<input type="checkbox"/> Installation according to instructions <input type="checkbox"/> Proper setting for measurement <input type="checkbox"/> Proper management 1 <input type="checkbox"/> Proper management 2; Basic management for 19' rack & ladder <input type="checkbox"/> Proper management 3; Management quality <input type="checkbox"/> Proper cable route 1 <input type="checkbox"/> Proper cable route 2 <input type="checkbox"/> Patch cord <input type="checkbox"/> Label <input type="checkbox"/> Correct label		
A3	Module 1 : Mount	<input type="checkbox"/> Proper mounting position		

A4	Module 1 : Optical box(Wall mount)	<input type="radio"/> Proper mounting condition <input type="radio"/> Installation completely <input type="radio"/> Proper cable fixing condition <input type="radio"/> Proper cable preparation <input type="radio"/> Storing condition <input type="radio"/> Proper connection; Quality (Quality, Fixing tray/ fiber, tube, heating) <input type="radio"/> Proper Spare fiber condition	
A5	Module 1 : Optical box(1F)	<input type="radio"/> Installation completely <input type="radio"/> Proper cable fixing condition <input type="radio"/> Proper cable preparation <input type="radio"/> Proper connection; Quality (Quality, Fixing tray/ fiber, tube, heating) <input type="radio"/> Proper Spare fiber condition <input type="radio"/> Storing condition	0 1 2 3
A6	Module 1 : Underground closure	<input type="radio"/> Installation completely <input type="radio"/> Proper cable fixing condition <input type="radio"/> Proper cable preparation <input type="radio"/> Proper connection; Quality(Quality, Fixing tray/ fiber, tube, heating) <input type="radio"/> Proper spare fiber condition <input type="radio"/> Storing condition	0 1 2 3
A7	Module 1 : Functionality	<input type="radio"/> STEP 1: Tested 1F(1)-(9) & 1F(2)-(10) <input type="radio"/> STEP 2: Tested 1F(1)-(9) & 1F(2)-(10) <input type="radio"/> STEP 2: Insertion Loss test 1F(1)-(9) & 1F(2)-(10) <input type="radio"/> STEP 3: OTDR 1F(15)-(17) & 1F(16)-(18)	
A8	Module 1 : Process	<input type="radio"/> Process O1 correct <input type="radio"/> Process O2 correct	

		O	Process O3 correct	
		J	Process J1 correct (Scheduling, Professional manner,Cleaning w	0 1 2 3
		J	Process J2 correct (Scheduling, Professional manner,Cleaning w	0 1 2 3
		J	Process J3 correct (Scheduling, Professional manner,Cleaning w	0 1 2 3
		J	Process J4 correct (Scheduling, Professional manner,Cleaning w	0 1 2 3
		J	Process J5 correct (rule violation)	0 1 2 3
A9	Module 1 : Completion			
A10	Module 1 : Safety	O	Finish Step 1 completely	
		O	Finish Step 2 completely	
		O	Finish Step 3 completely	
		O	No breach of the safety requirement during M1	
Sub Criteria ID	Sub Criteria Name or Description	Aspect Type O = Obj S = Sub J = Judg	Aspect - Description	Judg Score

B1	Module 2 ; Understanding test project	<input type="radio"/> Installation according to instructions <input type="radio"/> Proper setting for measurement	
B2	Module 2 : Cable management	<input type="radio"/> Proper management 1 <input type="radio"/> Proper management 2; Basic management for 19' rack <input type="radio"/> Proper management 3; Basic management for ladder <input type="radio"/> Proper management 4; Cable slack <input type="radio"/> Proper cable route 1 <input type="radio"/> Proper cable route 2 <input type="radio"/> Patch cord <input type="radio"/> Label <input type="radio"/> Correct label <input type="radio"/> J Proper management 5; Management quality	0 1 2 3
B3	Module 2 : Mount	<input type="radio"/> Proper mounting position <input type="radio"/> Proper mounting condition	
B4	Module 2 : Optical box(TO-2)	<input type="radio"/> Installation completely <input type="radio"/> Proper cable fixing condition <input type="radio"/> Proper cable preparation <input type="radio"/> Storing condition (bending, twist, management, heating sleeve) <input type="radio"/> Proper spare fiber condition	
B5	Module 2 : Optical box(1E&2E)	<input type="radio"/> Installation completely <input type="radio"/> Proper cable fixing condition <input type="radio"/> Proper cable preparation <input type="radio"/> Storing condition <input type="radio"/> Proper connection; Quality(Quality, Fixing tray/ fiber, tube, heating sleeve) <input type="radio"/> Proper spare fiber condition	
B6	Module 2 : Copper panel(1A&2A)	<input type="radio"/> Installation completely <input type="radio"/> Proper cable preparation <input type="radio"/> Proper cable fixing condition <input type="radio"/> Proper termination 1; Basic	

B7	Module 2 : Copper panel(1B&2B)	<input type="radio"/> Proper termination 2; Quality <input type="radio"/> Installation completely <input type="radio"/> Proper Management Cable <input type="radio"/> Proper cable preparation <input type="radio"/> Proper termination	
B8	Module 2 : Copper panel(TO-1)	<input type="radio"/> Installation completely <input type="radio"/> Proper cable preparation <input type="radio"/> Proper cable slack inside raceway <input type="radio"/> Proper termination	
B9	Module 2 : Copper panel(1C&2C)	<input type="radio"/> Installation completely <input type="radio"/> Proper cable preparation <input type="radio"/> Proper cable fixing condition <input type="radio"/> Proper termination 1; Basic <input type="radio"/> Proper termination 2; Quality <input type="radio"/> Proper wire slack/route for 110 termination	
B10	Module 2 : Functionality	<input type="radio"/> Tested 1E(5)-(7) & 1E(6)-(8) <input type="radio"/> Tested 2E(1)-(3) & 1E(2)-(4) <input type="radio"/> Tested 1B(X1)-1B(X2) & 1B(X3)-1B(X4) & 1B(X5)-1B(X6) <input type="radio"/> Tested 2B(X1)-TO1(1) & 2B(X3)-TO2(1) & 2B(X5)-TO3(1) <input type="radio"/> Tested 1C(X1)-1C(X2) & 1C(X3)-1C(X4) & 1C(X5)-1C(X6) <input type="radio"/> Certification test 1A(X1)-1A(X2) & 1A(X3)-1A(X4) & 1A(X5)-1A(X6)	
B11	Module 2 : Process	<input type="radio"/> Process O1 correct <input type="radio"/> Process O2 correct <input type="radio"/> Process O3 correct <input type="radio"/> Process J1 correct (Scheduling, Professional manner,Cleaning w	0 1 2 3
		<input type="radio"/> Process J2 correct (Scheduling, Professional manner,Cleaning w	0 1 2 3

		J	Process J3 correct (Scheduling, Professional manner,Cleaning w	0 1 2 3
		J	Process J4 correct (Scheduling, Professional manner,Cleaning w	0 1 2 3
B12	Module 2 : Completion	J	Process J5 correct (rule violation)	0 1 2 3
B13	Module 2 : Safety	O	Finish Optional task completely	
		O	No breach of the safety requirement during M2	
Sub Criteria ID	Sub Criteria Name or Description	Aspect Type O = Obj S = Sub J = Judg	Aspect - Description	Judg Score
C1	Module 3 ; Understanding test project			
		O	Installation according to instructions	
		O	Proper confuguration of WIFI	
C2	Module 3 : Cable management			
		O	Proper management 1	
		O	Patch cord	
		O	Correct label	
C3	Module 3 : Mount			
		O	Proper mounting position	
		O	Proper mounting condition	
C4	Module 3 : Optical panel (3D) & TO			
		O	Missing material.	
C5	Module 3 : Copper panel (3B&3C) & TO			

C6	Module 3 : Coaxial panel (3A) & TO	<input type="radio"/>	Installation completely	
		<input type="radio"/>	Proper cable preparation	
		<input type="radio"/>	Proper termination 1; Basic	
		<input type="radio"/>	Proper cable management	
		<input type="radio"/>	Patch cord	
C7	Module 3 : Functionality	<input type="radio"/>	Installation completely	
		<input type="radio"/>	Proper cable fixing condition	
		<input type="radio"/>	Proper termination	
		<input type="radio"/>	Proper cable management	
		<input type="radio"/>	Patch cord	
C8	Module 3 : Process	<input type="radio"/>	Connect Wifi link	
		<input type="radio"/>	Tested 3A(X)-TO4(X) & 3C(X)-TO4(X)	
		<input type="radio"/>	Tested 3D(X)-TO1(X)	
		<input type="radio"/>	Process O1 correct	
		<input type="radio"/>	Process O2 correct	
		<input type="radio"/>	Process O3 correct	
		J	Process J1 correct (Wifi configuration)	0
				1
				2
				3
		J	Process J2 correct (Scheduling, Professional manner,Cleaning w	0
				1
				2
				3
		J	Process J3 correct (Scheduling, Professional manner,Cleaning w	0
				1
				2
				3
		J	Process J4 correct (rule violation)	0
				1
				2
				3

C9	Module 3 : Completion			
C10	Module 3 : Safety			
		O	Finish task completely	
		O	No breach of the safety requirement during M3	
Sub Criteria ID	Sub Criteria Name or Description	Aspect Type O = Obj S = Sub J = Judg	Aspect - Description	Judg Score
D1	Module 4 : Functionality			
		O	Insertion loss of splice connections	
		O	troubleshooting	
D2	Module 4 : Process			
		O	Process O1 correct	
		O	Process O2 correct	
D3	Module 4 : Completion			
		O	Finish X splicing 1	
		O	Finish X splicing 2	
D4	Module 4 : Safety			
		O	No breach of the safety requirement during M4	
Sub Criteria ID	Sub Criteria Name or Description	Aspect Type O = Obj S = Sub J = Judg	Aspect - Description	Judg Score
E1	Module 5 ; Understanding test project			
		O	Installation according to instructions	
		O	Proper setting for measurement 1: Optical	
		O	Proper setting for measurement 2: Copper	
E2	Module 5 : Process			
		O	Process O1 correct	
		O	Process O2 correct	
		O	Process O3 correct	
E3	Module 5 : Completion			
		O	Finish task completely	

E4	Module 5 : Safety	O	No breach of the safety requirement during M5	
----	-------------------	---	---	--

Extra Aspect Description (Obj or Subj) OR Judgement Score Description (Judg only)	Requirement or Nominal Size (Obj Only)	WSSS Section	Max Mark
major mistake following guideline		2	0.50
		9	1.00
Usage of Management panel/ring/cable ladder		4	0.10
Slack, Bending radius, Stress, Fixing, Maintenance		4	0.30
meets the industry standard		4	0.20
cable route		4	0.10
cable entry to panel/rack/box		4	0.20
meet the industry standard		4	0.10
meet the skill standard		4	0.50
Complete		4	0.50
enclosure / box and 1F panel position		5	0.30

Criterion
A

Total
Mark

27.00

Firmly/Torque,Number of screw, cover condition		5	0.20
		5	0.50
TM length, Firmly/Torque, Tie		5	0.10
Loose tube stripping/ Jelly removing condition		5	0.10
Bending, twist, method, management		5	0.50
meet the industry standard		5	0.30
length, storing, fixing		3	0.20
		5	0.50
TM length, Firmly/Torque, Tie		5	0.30
Loose tube stripping/ Jelly removing condition		5	0.30
meet the industry standard		5	0.30
length, storing, fixing		3	0.40
		5	0.80
does not meet the industry standard			
meets the industry standard			
meets the industry standard and exceeds it in some aspect			
is excellent relative to the industry standard			
		5	1.00
TM length, Firmly/Torque, Tie		5	0.50
Loose tube stripping/ Jelly removing condition		5	0.50
does not meet the industry standard(0)		5	0.70
meets the industry standard(0.7)			
length, storing, fixing		3	0.40
		5	1.50
does not meet the industry standard			
meets the industry standard			
meets the industry standard and exceeds it in some aspect			
is excellent relative to the industry standard			
Visible light check ; mark 1		4	1.50
Visible light check ; mark 1		4	1.00
if each link satisfy ; mark 1	< Standard	4	1.00
if each link satisfy ; mark1	< Standard	5	1.50
Tools, Equipments		1	0.60
Test (method/cleaning)		9	0.60

Handling cable		4	0.60
		8	0.80
does not meet the skill standard			
meets the skill standard			
meets the skill standard and exceeds it in some aspects			
is excellent relative to the skill standard		8	0.80
does not meet the skill standard			
meets the skill standard			
meets the skill standard and exceeds it in some aspects			
is excellent relative to the skill standard		3	0.80
does not meet the skill standard			
meets the skill standard			
meets the skill standard and exceeds it in some aspects			
is excellent relative to the skill standard		4	0.80
does not meet the skill standard			
meets the skill standard			
meets the skill standard and exceeds it in some aspects			
is excellent relative to the skill standard		4	1.00
does not meet the skill standard			
meets the skill standard			
meets the skill standard and exceeds it in some aspects			
is excellent relative to the skill standard			
No error: 1.5 mark		1	1.50
No error: 0.3 mark		1	0.30
No error: 0.3 mark		1	0.30
Safety glasses, keeping worksite clean, access to high wo		1	1.00
Extra Aspect Description (Obj or Subj) OR Judgement Score Description (Judg only)	Requirement or Nominal Size (Obj Only)	WSSS Section	Max Mark

Criterion B Total Mark 40.00

	2	0.50
	9	1.00
Usage of Management panel/ring/cable ladder	4	0.20
Bending radius, Stress, Fixing	4	0.50
Bending radius, Stress, Fixing, Maintenance	4	0.50
Slack	3	0.50
cable route, slack	3	0.50
cable entry to panel/rack/box	4	0.20
meet the industry standard	4	0.20
meet the skill standard	4	0.50
Complete	4	1.00
	4	1.00
does not meet the industry standard		
meets the industry standard		
meets the industry standard and exceeds it in some aspects		
is excellent relative to the industry standard		
cable duct/ panel/ enclosure / box	5	0.50
Firmly/Torque,Number of screw, cover condition	5	0.50
	5	0.60
TM length, Firmly/Torque, Tie	5	0.20
Loose tube stripping/ Jelly removing condition	5	0.20
meet the industry standard	5	0.30
length, storing, fixing	3	0.10
	5	1.00
TM length, Firmly/Torque, Tie	5	0.20
Loose tube stripping/ Jelly removing condition	5	0.20
Bending, twist, method, management	5	0.50
meet the industry standard	5	0.40
length, storing, fixing	3	0.10
All connection terminated, modular mounting	6	1.50
S/F shield condition, edge of cable,	6	0.40
cable tie, firmly,	6	0.30
untwisted length, stress, sufficient insertion, wire condition	6	0.80

meet the industry standard		6	0.40
All connection terminated, modular mounting		6	1.00
Cable Tie, Firmly, meet the industry standard, wire condition		6	0.20
edge of cable, untwisted length, jacket removing condition		6	0.35
meet the industry standard ,untwisted length, sufficient insulation		6	0.55
All connection terminated, modular mounting		6	1.00
No damage to pair coating (Cuts)		6	0.20
For maintenance		6	0.30
untwisted length, stress, sufficient insertion, wire condition		6	0.50
All connection terminated, modular mounting		6	1.00
S/F shield condition, edge of cable,		6	0.20
cable tie, firmly,		6	0.20
untwisted length, stress, sufficient insertion, wire condition		6	0.50
meet the industry standard		6	0.30
sufficient slack, route		6	0.30
Visible light check ; mark 0.5	No weak	4	0.50
Visible light check ; mark 1	No weak	4	1.00
Wiremap check; mark 0.5	Pass	4	0.50
Wiremap check; mark 1	Pass	4	1.00
Wiremap check; mark 0.5	Pass	4	0.50
Permanent link test ; mark 2.5	Pass	6	2.50
Tools, Equipments		1	0.80
Test (method/cleaning)		9	0.80
Handling cable		4	0.80
		8	0.80
does not meet the industry standard			
meets the industry standard			
meets the industry standard and exceeds it in some aspects			
is excellent relative to the industry standard		8	0.90
does not meet the industry standard			
meets the industry standard			
meets the industry standard and exceeds it in some aspects			
is excellent relative to the industry standard			

does not meet the industry standard meets the industry standard meets the industry standard and exceeds it in some aspect is excellent relative to the industry standard		3	1.00
does not meet the industry standard meets the industry standard meets the industry standard and exceeds it in some aspect is excellent relative to the industry standard		4	1.00
does not meet the industry standard meets the industry standard meets the industry standard and exceeds it in some aspect is excellent relative to the industry standard		4	1.50
does not meet the industry standard meets the industry standard meets the industry standard and exceeds it in some aspect is excellent relative to the industry standard		3	4.00
Safety glasses, keeping worksite clean, access to high work		1	1.00
Extra Aspect Description (Obj or Subj) OR Judgement Score Description (Judg only)	Requirement or Nominal Size (Obj Only)	WSSS Section	Max Mark
		2	1.00
		7	1.50
Usage of Management tube meet the industry standard Meets the skill standard, cable/cables/panel/box		4	0.10
		4	0.10
		4	0.50
Camera / Wifi-router / 3A+Mngt+3B+ 3C panels		4	0.20
Firmly/Torque,Number of screw, Measurements		4	0.30
Everyone gets 1.0 points.		5	1.00

Criterion C Total Mark 21.00

All connection terminated, modular mounting	6	0.60
No damage to pair coating (Cuts)	6	0.20
untwisted length, stress, sufficient insertion, wire condition	6	0.50
Slack for maintenance	6	0.20
meet the industry standard	4	0.20
All connection terminated	4	0.60
F-connector properly screwed in	6	0.20
stress, sufficient insertion, conductor condition	6	0.40
Slack for maintenance	6	0.30
meet the industry standard	4	0.30
mark 1.5	7	1.50
Wiremap check; mark 1	4	1.00
Visible light check; mark 0.5	9	1.00
Tools, Equipments	1	0.60
Test (method/cleaning)	7	0.60
Handling cable	4	0.60
	7	1.00
does not meet the industry standard		
meets the industry standard		
meets the industry standard and exceeds it in some aspects		
is excellent relative to the industry standard	8	1.00
does not meet the industry standard		
meets the industry standard		
meets the industry standard and exceeds it in some aspects		
is excellent relative to the industry standard	3	1.00
does not meet the industry standard		
meets the industry standard		
meets the industry standard and exceeds it in some aspects		
is excellent relative to the industry standard	4	1.50
does not meet the industry standard		
meets the industry standard		
meets the industry standard and exceeds it in some aspects		
is excellent relative to the industry standard		

		3	2.00
Safety glasses, keeping worksite clean, access to high wo		1	1.00
Extra Aspect Description (Obj or Subj) OR Judgement Score Description (Judg only)	Requirement or Nominal Size (Obj Only)	WSSS Section	Max Mark
each splicing; mark 1	<1.0dB	9 8	1.00 0.50
Tools, Equipments Handling fiber		1 3	0.50 0.50
30 splices: 0.5 mark +10' splices; 0.5 mark		4 5	0.50 1.50
Safety glasses		1	0.50
Extra Aspect Description (Obj or Subj) OR Judgement Score Description (Judg only)	Requirement or Nominal Size (Obj Only)	WSSS Section	Max Mark
		2 5 6	1.00 1.00 1.00
Tools, Equipments Test (method/cleaning) Trouble shooting (Splicing)		3 8 8	1.00 0.70 0.30
		4	1.00

Criterion D Total Mark 5.00

Criterion E Total Mark 7.00

Safety glasses		1	1.00
----------------	--	---	------

Competition Total Mark 100.00